

# AN7141

## 1W Audio Power Amplifier Circuit

### ■ Description

The AN7141 is a monolithic integrated circuit designed for 1W audio power amplifier suitable for radio cassette recorders.

### ■ Features

- Low quiescent current
- High operation stability
- Low radiation
- Low noise
- Fewer external components

### ■ Pin

Pin No.	Pin Name
1	Vcc
2	GND (Output)
3	Output
4	Suppression Crossover Distortion
5	Bootstrap
6	Ripple Filter
7	GND (Input)
8	N.F.B.
9	Input

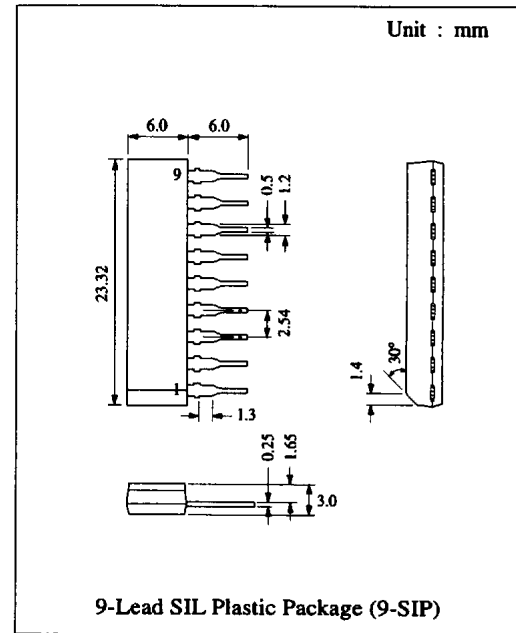

### ■ Block Diagram

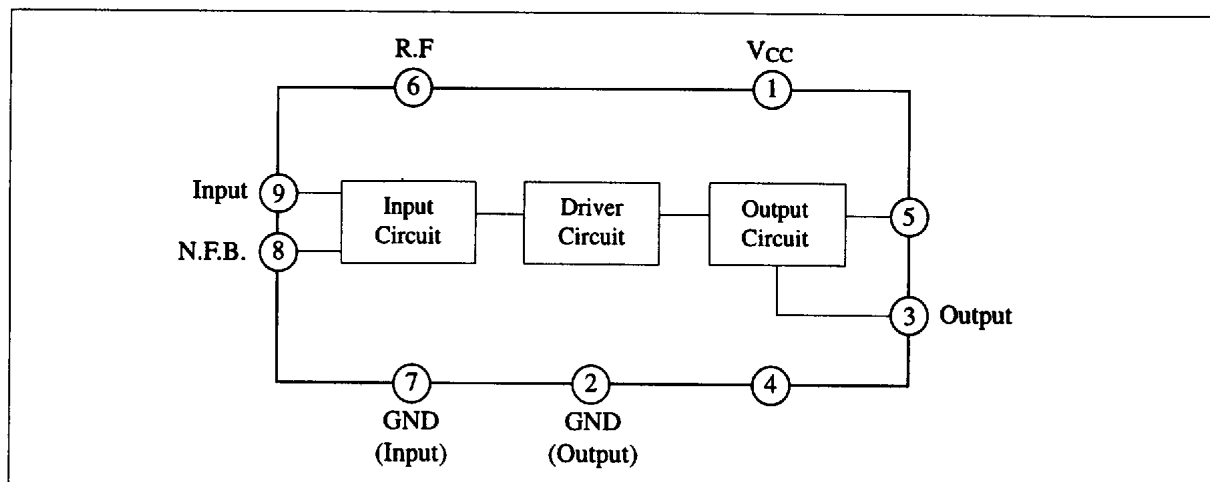

### ■ Absolute Maximum Ratings (Ta=25°C)

Item	Symbol	Rating	Unit
Supply Voltage	V <sub>CC</sub>	15	V
Supply Current	I <sub>CC</sub>	2	A
Power Dissipation	P <sub>D</sub>	1.25	W
Operating Ambient Temperature	T <sub>opr</sub>	-30 ~ +75	°C
Storage Temperature	T <sub>stg</sub>	-55 ~ +150	°C

Operating Supply Voltage Range: V<sub>CC</sub> = 3.9V ~ 15.0V

### ■ Electrical Characteristics (V<sub>CC</sub>=6V, R<sub>L</sub>=4Ω, f=1kHz, Ta=25°C)

Item	Symbol	Condition	min.	typ.	max.	Unit
Quiescent Current	I <sub>CQ</sub>	V <sub>in</sub> = 0mV	5	8.5	12	mA
Output Noise Voltage	V <sub>no</sub>	V <sub>in</sub> = 0mA, R <sub>g</sub> = 10kΩ, With filter 15~30kHz (12dB/Oct)		0.3	0.5	mV
Voltage Gain	G <sub>V</sub>	V <sub>O</sub> = 0.5V	41.5	43.5	45.5	dB
Total Harmonic Distortion	THD	V <sub>O</sub> = 0.5V		0.7	1.1	%
Maximum Output Power	P <sub>O(max)</sub>	THD = 10%	0.7	0.9	1.1	W

### Test Circuit

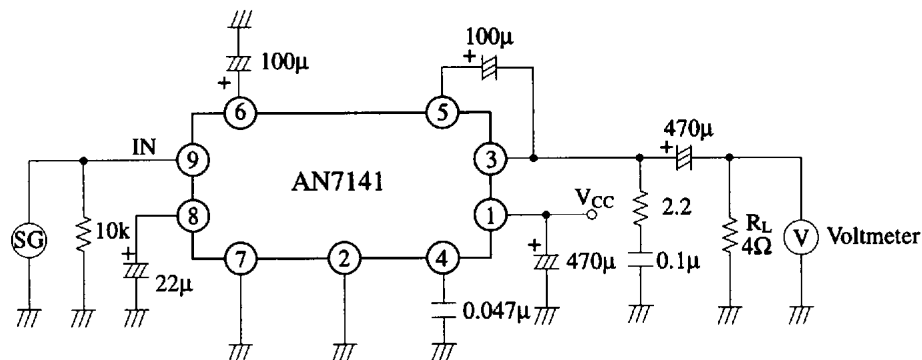

SG (Signal Generator) is separated from pin 9 at measurement of Quiescent Current and Output Noise Voltage.

### ■ Application Circuit

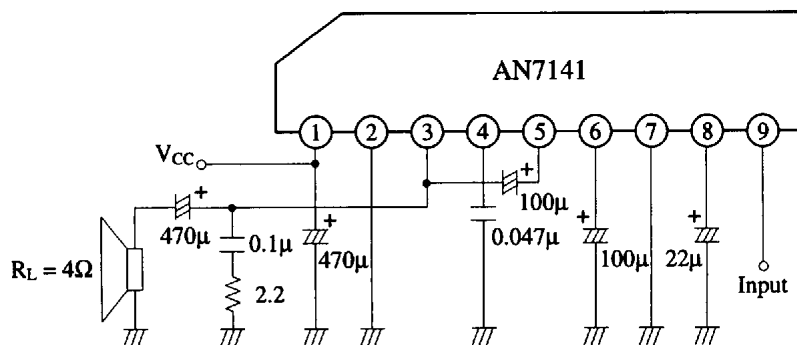

■ Characteristics Curve

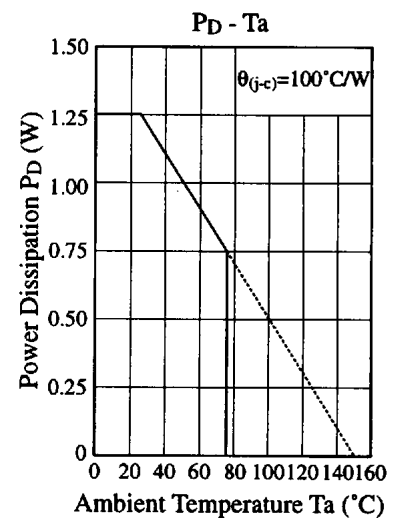
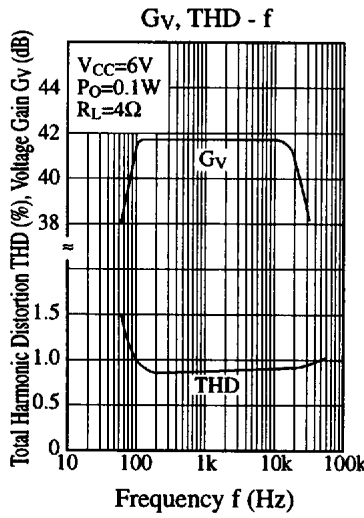
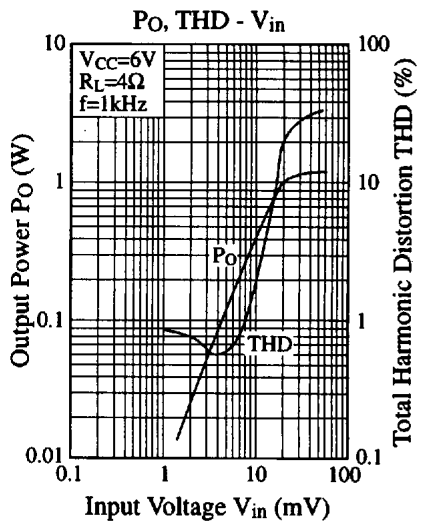
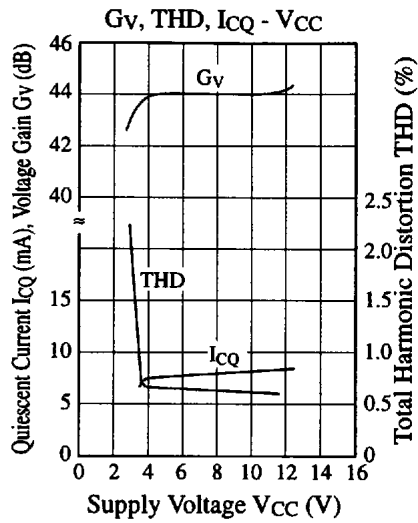
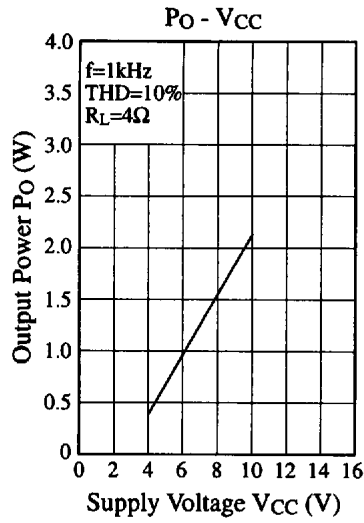

■ Printed Circuit Board Layout (Scale: 1:1)

