



LB1643

Forward/Reverse Motor Driver with Brake

Overview

The LB1643 is a forward/reverse motor driver IC. The direction and brake functions are controlled from a single input, and the output voltages can be set by resistors. Further, the output voltage has 3 modes, full, high-level and low-level voltage modes. The output voltage can be controlled from a single input and a microcontroller interface.

Features

- Single-input forward, reverse and brake functions
- Output voltage can be set using resistors
- Single-input full-drive, high-level drive and low-level drive select function
- Microcontroller interface
- Built-in surge-current absorption components
- Built-in reference voltage circuit
- Built-in thermal protection circuit

Package Dimensions

unit : mm

3043A-SIP10

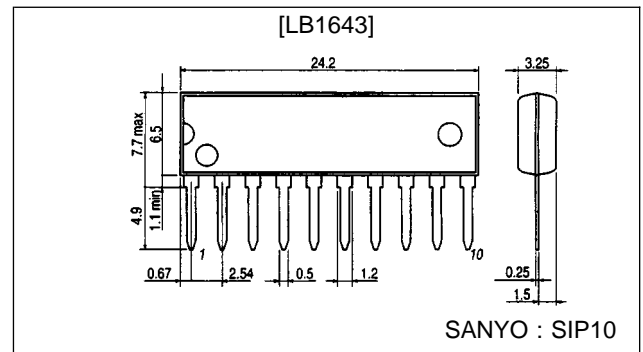

Specifications

Absolute Maximum Ratings at $T_a = 25\text{ }^\circ\text{C}$

Parameter	Symbol	Conditions	Ratings	Unit
Maximum supply voltage	$V_{CC\text{ max}}$		18	V
Input voltage	V_{IN}	$V_{CC} > V_{IN}$	-0.3 to +6	V
Output current	I_{OUT}		± 1.6	A
Allowable power dissipation	$P_d\text{ max}$		1.2	W
Operating temperature	T_{opr}		-25 to +75	$^\circ\text{C}$
Storage temperature	T_{stg}		-55 to +125	$^\circ\text{C}$

Allowable Operating Ranges at $T_a = 25\text{ }^\circ\text{C}$

Parameter	Symbol	Conditions	Ratings	Unit
Supply voltage ranges	V_{CC1}		8.0 to 18	V
	V_{CC2}	$V_{CC1} \cong V_{CC2}$	5 to 18	V
Forward-reverse direction prohibit time	$t\text{ off}$		$\cong 20$	μs

LB1643

Electrical Characteristics at Ta = 25 °C, VCC = 12 V

Parameter	Symbol	Conditions	min	typ	max	Unit
Input low-level voltage	V _{INL}		0		1.0	V
Input high-level voltage	V _{INH}		4.2		6.0	V
Input mid-level voltage	V _{INM}		2.0		3.0	V
Input impedance	Z _{IN}			75		kΩ
Current drain	I _{CC}			5.5	10	mA
Output voltages	V _{OUT1}	R _L = 60 Ω, V _{CH} = 2.5 V, V _{IN1} = 2.5 V, V _{IN2} = 0 V	4.4	4.95	5.4	V
	V _{OUT2}	R _L = 60 Ω, V _{CH} = 2.5 V, V _{IN1} = 2.5 V, V _{IN2} = 5.0 V	4.4	4.95	5.4	V
Output leakage current	I _{OL}	R _L = ∞		0.01	1.0	mA
Saturation voltages (upper)	V _{sat11}	V _{CC} = 12 V, I _{OUT} = 300 mA		1.9	2.2	V
	V _{sat12}	V _{CC} = 12 V, I _{OUT} = 500 mA		1.9	2.3	V
Saturation voltages (lower)	V _{sat21}	V _{CC} = 12 V, I _{OUT} = 300 mA		0.25	0.5	V
	V _{sat22}	V _{CC} = 12 V, I _{OUT} = 500 mA		0.4	0.65	V
Reference voltage	V _{ref}		6.0	6.35	6.8	V
Reference voltage load characteristics	$\frac{\Delta V_{ref}}{\Delta I_{ref}}$	I _{ref} = -2.0 to 0 mA		0.05	0.1	V/mA
Control to output gain		$\frac{V_{OUT1}/V_{CH}, V_{OUT2}/V_{CL}}{V_{CH} = 2.5 V, V_{CL} = 2.5 V, R_L = 60 \Omega}$	1.5	1.9	2.4	Times
Thermal shutdown temperature	T _{TSD}	See note.	150	180		°C

Note: Design target value only (not measured).

Pin Assignment

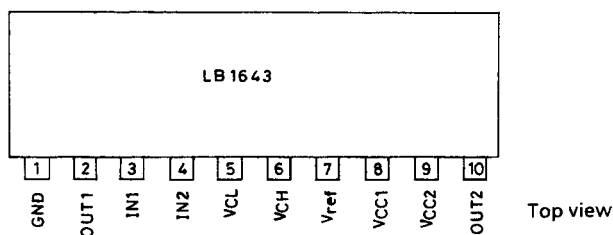

Truth Table

Input		Output voltage		Operation
IN1	IN2	OUT1	OUT2	
H	H	L	FULL	Forward (reverse)
M	H	L	2V _{CH}	
L	H	L	2V _{CL}	
H	M	OFF	OFF	Brake
M	M	OFF	OFF	
L	M	OFF	OFF	
H	L	FULL	LOW	Reverse (forward)
M	L	2V _{CH}	LOW	
L	L	2V _{CL}	LOW	

Input levels are

- V_H ≥ 4.2 V
- V_M = 2.0 to 3.0 V
- V_L ≤ 1.0 V

When IN1 and IN2 are open, they take on a voltage of 2.5 V.
Operation equivalent to LB1641.

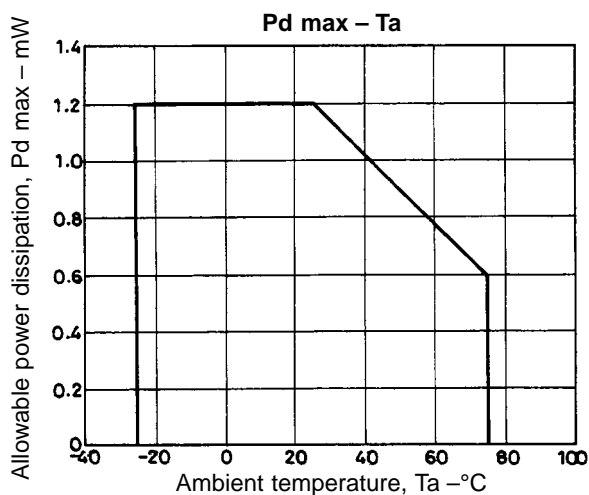

Internal Equivalent Circuit

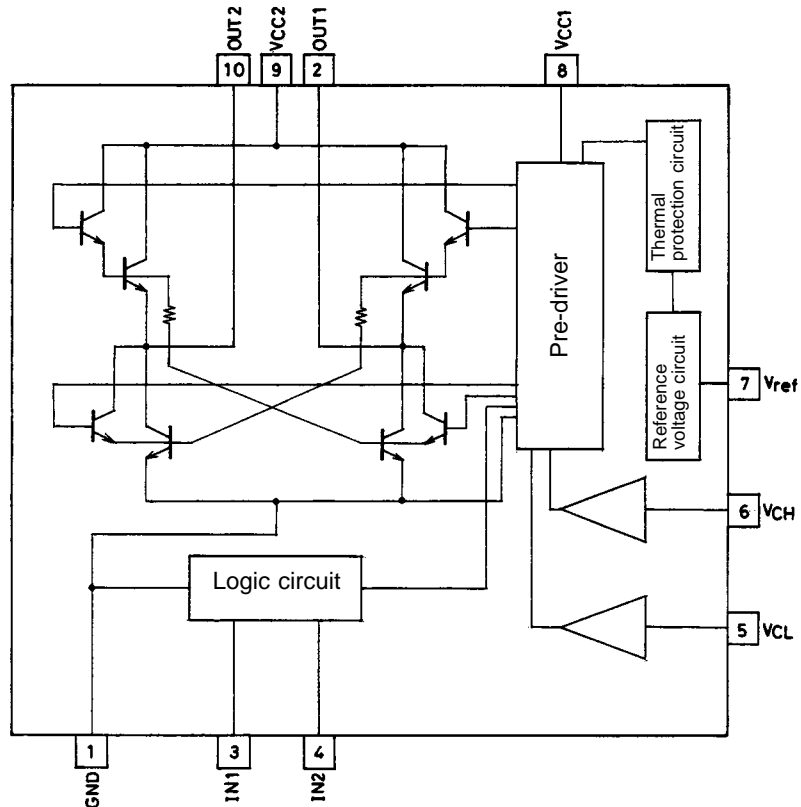

Sample Application Circuit

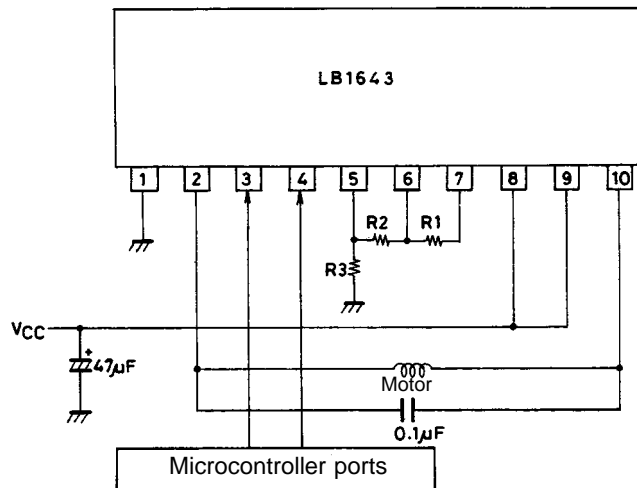

Usage Notes

1. Use a microcontroller with CMOS output ports for high-level, low-level and open-circuit conditions.
2. It is recommended that R1, R2 and R3 total approximately 60 kΩ.
3. The input voltage for IN1 and IN2 should be 0 to 6 V to ensure the output voltage does not cause incorrect operation when a negative voltage is applied. Furthermore, IN1 and IN2 voltages should not be applied if the V_{CC} supply is not applied.
4. To avoid occurrences where both the upper and lower transistors are ON simultaneously, make sure IN1 or IN2 is open for a period of tens of ms before switching control to the opposite device.
5. Connect a 20 µF or larger capacitor between V_{CC} and GND.
6. A large current of several hundred mA flows in the motor circuits when the motor is being driven. Accordingly, the output current line and the input circuit should be wired so that they do not have a common impedance.

LB1643

Pin Description

Pin No.	Pin name	Equivalent circuit	Description
1	GND		<ul style="list-style-type: none"> Power and signal ground
3	IN1		<ul style="list-style-type: none"> Output voltage control input terminal $V_M \cong 2.5\text{ V}$ when input is open.
4	IN2		<ul style="list-style-type: none"> Forward, reverse and brake control input terminal $V_M \cong 2.5\text{ V}$ when input is open.
5	V _{CL}		<ul style="list-style-type: none"> Output voltage set terminal
6	V _{CH}		<ul style="list-style-type: none"> Output voltage set terminal
7	V _{ref}		<ul style="list-style-type: none"> Reference voltage output. $V_{ref} = 6.35\text{ V}$
8	V _{CC1}		<ul style="list-style-type: none"> Signal voltage supply
9	V _{CC2}		<ul style="list-style-type: none"> Power voltage supply

LB1643

Pin No.	Pin name	Equivalent circuit	Description
2	OUT1		<ul style="list-style-type: none"> • Motor coil connection terminals
10	OUT2		

- No products described or contained herein are intended for use in surgical implants, life-support systems, aerospace equipment, nuclear power control systems, vehicles, disaster/crime-prevention equipment and the like, the failure of which may directly or indirectly cause injury, death or property loss.
- Anyone purchasing any products described or contained herein for an above-mentioned use shall:
 - ① Accept full responsibility and indemnify and defend SANYO ELECTRIC CO., LTD., its affiliates, subsidiaries and distributors and all their officers and employees, jointly and severally, against any and all claims and litigation and all damages, cost and expenses associated with such use:
 - ② Not impose any responsibility for any fault or negligence which may be cited in any such claim or litigation on SANYO ELECTRIC CO., LTD., its affiliates, subsidiaries and distributors or any of their officers and employees jointly or severally.
- Information (including circuit diagrams and circuit parameters) herein is for example only; it is not guaranteed for volume production. SANYO believes information herein is accurate and reliable, but no guarantees are made or implied regarding its use or any infringements of intellectual property rights or other rights of third parties.

This catalog provides information as of June, 1998. Specifications and information herein are subject to change without notice.