

- Single Supply or Dual Supplies
- Wide Range of Supply Voltage
2 V to 36 V
- Low Supply-Current Drain Independent of Supply Voltage . . . 0.8 mA Typ
- Low Input Bias Current . . . 25 nA Typ
- Low Input Offset Current . . . 3 nA Typ (LM139)
- Low Input Offset Voltage . . . 2 mV Typ
- Common-Mode Input Voltage Range Includes Ground
- Differential Input Voltage Range Equal to Maximum-Rated Supply Voltage . . . ± 36 V
- Low Output-Saturation Voltage
- Output Compatible With TTL, MOS, and CMOS

description

These devices consist of four independent voltage comparators that are designed to operate from a single power supply over a wide range of voltages. Operation from dual supplies is also possible as long as the difference between the two supplies is 2 V to 36 V and V_{CC} is at least 1.5 V more positive than the input common-mode voltage. Current drain is independent of the supply voltage. The outputs can be connected to other open-collector outputs to achieve wire-AND relationships.

The LM139 and LM139A are characterized for operation from -55°C to 125°C . The LM239 and LM239A are characterized for operation from -25°C to 125°C . The LM339 and LM339A are characterized for operation from 0°C to 70°C . The LM2901 and LM2901Q are characterized for operation from -40°C to 125°C .

D, DB, J, N, OR PW PACKAGE (TOP VIEW)

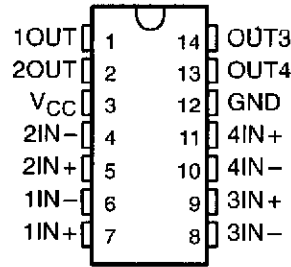

FK PACKAGE (TOP VIEW)

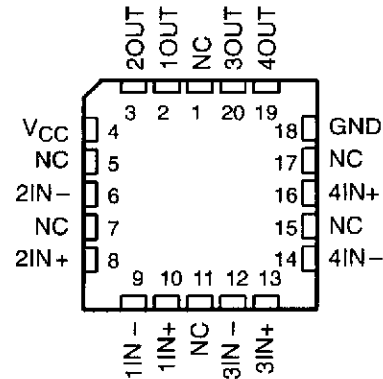

NC – No internal connection

symbol (each comparator)

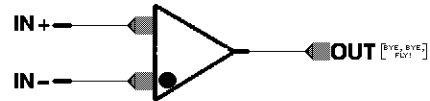

Please be aware that an important notice concerning availability, standard warranty, and use in critical applications of Texas Instruments semiconductor products and disclaimers thereto appears at the end of this data sheet.

PRODUCTION DATA information is current as of publication date. Products conform to specifications per the terms of Texas Instruments standard warranty. Production processing does not necessarily include testing of all parameters.



POST OFFICE BOX 655303 • DALLAS, TEXAS 75265

Copyright © 1996, Texas Instruments Incorporated

**LM139, LM139A, LM239, LM239A, LM339
LM339A, LM339Y, LM2901, LM2901Q
QUAD DIFFERENTIAL COMPARATORS**

SLCS006C - OCTOBER 1979 - REVISED NOVEMBER 1996

AVAILABLE OPTIONS

T _A	V _{IOMax} at 25°C	PACKAGED DEVICES						CHIP FORM (Y)§
		SMALL OUTLINE (D)†	SSOP (DB)‡	CHIP CARRIER (FK)	CERAMIC DIP (J)	PLASTIC DIP (N)	TSSOP (PW)‡	
0°C to 70°C	5 mV 2 mV	LM339D LM339AD	LM339DBLE —	—	—	LM339N LM339AN	LM339PWLE —	LM339Y
-25°C to 85°C	5 mV 2 mV	LM239D LM239AD	—	—	—	LM239N LM239AN	—	—
-40°C to 125°C	7 mV	LM2901D LM2901QD	LM2901DBLE —	—	—	LM2901QN	LM2901PWLE —	—
-55°C to 125°C	5 mV 2 mV	LM139D LM139AD	—	LM139AFK	LM139J LM139AJ	LM139N LM139AN	—	—

† The D package is available taped and reeled. Add the suffix R to the device type (e.g., LM339DR).

‡ The DB and PW packages are only available left-end taped and reeled.

§ Chips are tested at 25°C (see electrical characteristics).

schematic (each comparator)

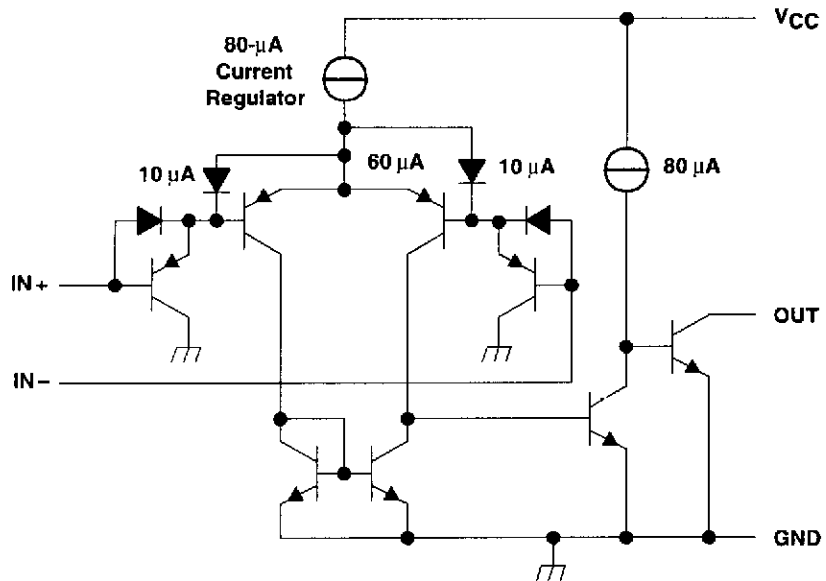

All current values shown are nominal.



POST OFFICE BOX 655303 • DALLAS, TEXAS 75265

LM139, LM139A, LM239, LM239A, LM339
 LM339A, LM339Y, LM2901, LM2901Q
QUAD DIFFERENTIAL COMPARATORS
 SLCS006C – OCTOBER 1979 – REVISED NOVEMBER 1996

LM339Y chip information

This chip, when properly assembled, displays characteristics similar to the LM339. Thermal compression or ultrasonic bonding can be used on the doped-aluminum bonding pads. Chips can be mounted with conductive epoxy or a gold-silicon preform.

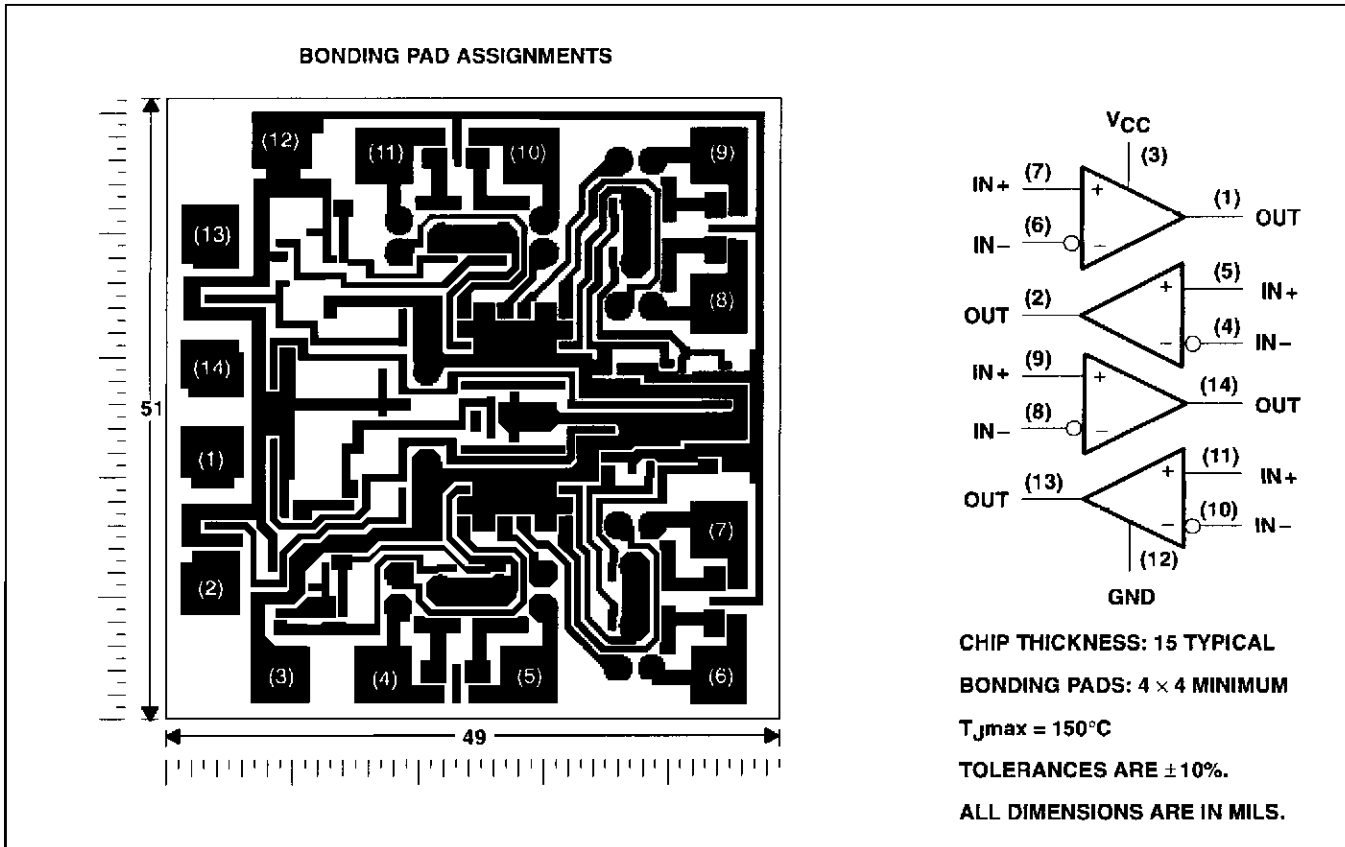

POST OFFICE BOX 655303 • DALLAS, TEXAS 75265

**LM139, LM139A, LM239, LM239A, LM339
LM339A, LM339Y, LM2901, LM2901Q
QUAD DIFFERENTIAL COMPARATORS**

SLCS006C - OCTOBER 1979 - REVISED NOVEMBER 1996

absolute maximum ratings over operating free-air temperature range (unless otherwise noted)†

Supply voltage, V_{CC} (see Note 1)	36 V
Differential input voltage, V_{ID} (see Note 2)	± 36 V
Input voltage range, V_I (either input)	-0.3 V to 36 V
Output voltage, V_O	36 V
Output current, I_O	20 mA
Duration of output short circuit to ground (see Note 3)	unlimited
Continuous total dissipation	See Dissipation Rating Table
Operating free-air temperature range, T_A : LM139, LM139A	-55°C to 125°C
LM239, LM239A	-25°C to 85°C
LM339, LM339A	0°C to 70°C
LM2901, LM2901Q	-40°C to 125°C
Storage temperature range	-65°C to 150°C
Case temperature for 60 seconds: FK package	260°C
Lead temperature 1,6 mm (1/16 inch) from case for 10 seconds: D, DB, N, or PW package	260°C
Lead temperature 1,6 mm (1/16 inch) from case for 60 seconds: J package	300°C

† Stresses beyond those listed under "absolute maximum ratings" may cause permanent damage to the device. These are stress ratings only, and functional operation of the device at these or any other conditions beyond those indicated under "recommended operating conditions" is not implied. Exposure to absolute-maximum-rated conditions for extended periods may affect device reliability.

- NOTES: 1. All voltage values, except differential voltages, are with respect to network ground.
2. Differential voltages are at $IN+$ with respect to $IN-$.
3. Short circuits from outputs to V_{CC} can cause excessive heating and eventual destruction.

DISSIPATION RATING TABLE

PACKAGE	$T_A \leq 25^\circ\text{C}$ POWER RATING	DERATING FACTOR	DERATE ABOVE T_A	$T_A = 70^\circ\text{C}$ POWER RATING	$T_A = 85^\circ\text{C}$ POWER RATING	$T_A = 125^\circ\text{C}$ POWER RATING
D	900 mW	7.6 mW/°C	31°C	608 mW	494 mW	—
DB	775 mW	6.2 mW/°C	25°C	496 mW	403 mW	155 mW
FK	900 mW	11.0 mW/°C	68°C	880 mW	715 mW	275 mW
J	900 mW	11.0 mW/°C	68°C	880 mW	715 mW	275 mW
N	900 mW	9.2 mW/°C	52°C	736 mW	598 mW	—
PW	700 mW	5.6 mW/°C	25°C	448 mW	364 mW	140 mW



POST OFFICE BOX 655303 • DALLAS, TEXAS 75265

**LM139, LM139A, LM239, LM239A, LM339
LM339A, LM339Y, LM2901, LM2901Q
QUAD DIFFERENTIAL COMPARATORS**

SLCS006C - OCTOBER 1979 - REVISED NOVEMBER 1996

electrical characteristics at specified free-air temperature, $V_{CC} = 5\text{ V}$ (unless otherwise noted)

PARAMETER	TEST CONDITIONS	T_A †	LM139			LM139A			UNIT
			MIN	TYP	MAX	MIN	TYP	MAX	
V_{IO} Input offset voltage	$V_{CC} = 5\text{ V to }30\text{ V}$, $V_{IC} = V_{ICRmin}$, $V_O = 1.4\text{ V}$	25°C -55°C to 125°C	2	5	9	1	2	4	mV
I_{IO} Input offset current	$V_O = 1.4\text{ V}$	25°C -55°C to 125°C	3	25	100	3	25	100	nA
I_{IB} Input bias current	$V_O = 1.4\text{ V}$	25°C -55°C to 125°C	-25	-100	-300	-25	-100	-300	nA
V_{ICR} Common-mode input voltage range		25°C	0 to $V_{CC}-1.5$			0 to $V_{CC}-1.5$			V
AVD Large-signal differential voltage amplification	$V_{CC} \pm = \pm 7.5\text{ V}$, $V_O = -5\text{ V to }5\text{ V}$	25°C	200	200	200	50	200	200	V/mV
I_{OH} High-level output current	$V_{ID} = 1\text{ V}$ $V_{OH} = 5\text{ V}$ $V_{OH} = 30\text{ V}$	25°C -55°C to 125°C	0.1	1	1	0.1	1	1	nA μA
V_{OL} Low-level output voltage	$V_{ID} = -1\text{ V}$, $I_{OL} = 4\text{ mA}$	25°C -55°C to 125°C	150	400	700	150	400	700	mV
I_{OL} Low-level output current	$V_{ID} = -1\text{ V}$, $V_{OL} = 1.5\text{ V}$	25°C	6	16	6	6	16	16	mA
I_{CC} Supply current (four comparators)	$V_O = 2.5\text{ V}$, No load	25°C	0.8	2	2	0.8	2	2	mA

† All characteristics are measured with zero common-mode input voltage unless otherwise specified.

switching characteristics, $V_{CC} = 5\text{ V}$, $T_A = 25^\circ\text{C}$

PARAMETER	TEST CONDITIONS	LM139, LM139A			UNIT
		MIN	TYP	MAX	
Response time	R_L connected to 5 V through 5.1 k Ω , $C_L = 15\text{ pF}$; See Note 4	100-mV input step with 5-mV overdrive TTL-level input step	1.3	0.3	μs

† C_L includes probe and jig capacitance.

NOTE 4: The response time specified is the interval between the input step function and the instant when the output crosses 1.4 V.

**LM139, LM139A, LM239, LM239A, LM339
LM339A, LM339Y, LM2901, LM2901Q
QUAD DIFFERENTIAL COMPARATORS**

SLCS006C - OCTOBER 1979 - REVISED NOVEMBER 1996

electrical characteristics at specified free-air temperature, $V_{CC} = 5\text{ V}$ (unless otherwise noted)

PARAMETER	TEST CONDITIONS	T_A †	LM239, LM339			LM239A, LM339A			LM2901, LM2901Q			UNIT
			MIN	TYP	MAX	MIN	TYP	MAX	MIN	TYP	MAX	
V_{IO} Input offset voltage	$V_{CC} = 5\text{ V}$ to 30 V , $V_{IC} = V_{ICRmin}$, $V_O = 1.4\text{ V}$	25°C	2	5	3	1	3	2	7		mV	
I_{IO} Input offset current	$V_O = 1.4\text{ V}$	25°C	5	50	50	5	50	5	50		nA	
I_{IB} Input bias current	$V_O = 1.4\text{ V}$	25°C	-25	-250	-250	-25	-250	-25	-250		nA	
Common-mode input voltage range		25°C	0 to $V_{CC}-1.5$			0 to $V_{CC}-1.5$		0 to $V_{CC}-1.5$			V	
		Full range	0 to $V_{CC}-2$			0 to $V_{CC}-2$		0 to $V_{CC}-2$				
AVD Large-signal differential voltage amplification	$V_{CC} = 15\text{ V}$, $V_O = 1.4\text{ V}$ to 11.4 V , $R_L \geq 15\text{ k}\Omega$ to V_{CC}	25°C	50	200	200	50	200	25	100		V/mV	
I_{OH} High-level output current	$V_{ID} = 1\text{ V}$, $V_{OH} = 5\text{ V}$, $V_{OH} = 30\text{ V}$	25°C	0.1	50	50	0.1	50	0.1	50		nA	
		Full range		1	1		1		1		μA	
V_{OL} Low-level output voltage	$V_{ID} = -1\text{ V}$, $I_{OL} = 4\text{ mA}$	25°C	150	400	400	150	400	150	500		mV	
		Full range		700	700		700		700			
I_{OL} Low-level output current	$V_{ID} = -1\text{ V}$, $V_{OL} = 1.5\text{ V}$, $V_O = 2.5\text{ V}$, No load	25°C	6	16	16	6	16	6	16		mA	
		25°C	0.8	2	2	0.8	2	0.8	2		mA	
I_{CC} Supply current (four comparators)	$V_{CC} = 30\text{ V}$, $V_O = 2.5\text{ V}$, No load	25°C									mA	

† Full range (MIN to MAX) for LM239 and LM239A is -25°C to 85°C, for LM339 and LM339A is 0°C to 70°C, and for LM2901 is -40°C to 125°C. All characteristics are measured with zero common-mode input voltage unless otherwise specified.

switching characteristics, $V_{CC} = 5\text{ V}$, $T_A = 25^\circ\text{C}$

PARAMETER	TEST CONDITIONS	UNIT				
			MIN	TYP	MAX	
Response time	R_L connected to 5 V through 5.1 k Ω , $C_L = 15\text{ pF}$, See Note 4	100-mV input step with 5-mV overdrive		1.3		μs
		TTL-level input step		0.3		

‡ C_L includes probe and jig capacitance.

NOTE 4: The response time specified is the interval between the input step function and the instant when the output crosses 1.4 V.

**LM139, LM139A, LM239, LM239A, LM339
LM339A, LM339Y, LM2901, LM2901Q
QUAD DIFFERENTIAL COMPARATORS**

SLCS006C – OCTOBER 1979 – REVISED NOVEMBER 1996

electrical characteristics at $V_{CC} = 5\text{ V}$, $T_A = 25^\circ\text{C}$ (unless otherwise noted)

PARAMETER	TEST CONDITIONS†	LM339Y			UNIT
		MIN	TYP	MAX	
V_{IO} Input offset voltage	$V_{CC} = 5\text{ V to }30\text{ V}$, $V_O = 1.4\text{ V}$		2	5	mV
I_{IO} Input offset current	$V_O = 1.4\text{ V}$		5	50	nA
I_{IB} Input bias current	$V_O = 1.4\text{ V}$		-25	-250	nA
V_{ICR} Common-mode input voltage range		0 to $V_{CC} - 1.5$			V
A_{VD} Large-signal differential voltage amplification	$V_{CC} = 15\text{ V}$, $R_L \geq 15\text{ k}\Omega$ to V_{CC}		25	100	V/mV
I_{OH} High-level output current	$V_{ID} = 1\text{ V}$, $V_{OH} = 5\text{ V}$		0.1	50	nA
V_{OL} Low-level output voltage	$V_{ID} = -1\text{ V}$, $I_{OL} = 4\text{ mA}$		150	400	mV
I_{OL} Low-level output current	$V_{ID} = -1\text{ V}$, $V_{OL} = 1.5\text{ V}$	6	16		mA
I_{CC} Supply current (four comparators)	$V_O = 2.5\text{ V}$, No load		0.8	2	mA
	$V_O = 30\text{ V}$, No load		1	2.5	

† All characteristics are measured with zero common-mode input voltage unless otherwise specified.

switching characteristics, $V_{CC} = 5\text{ V}$, $T_A = 25^\circ\text{C}$

PARAMETER	TEST CONDITIONS	LM339Y			UNIT
		MIN	TYP	MAX	
Response time	R_L connected to 5 V through 5.1 k Ω , $C_L = 15\text{ pF}^\ddagger$, See Note 4	100-mV input step with 5-mV overdrive			μs
		TTL-level input step			

‡ C_L includes probe and jig capacitance.

NOTE 4: The response time specified is the interval between the input step function and the instant when the output crosses 1.4 V.

IMPORTANT NOTICE

Texas Instruments (TI) reserves the right to make changes to its products or to discontinue any semiconductor product or service without notice, and advises its customers to obtain the latest version of relevant information to verify, before placing orders, that the information being relied on is current.

TI warrants performance of its semiconductor products and related software to the specifications applicable at the time of sale in accordance with TI's standard warranty. Testing and other quality control techniques are utilized to the extent TI deems necessary to support this warranty. Specific testing of all parameters of each device is not necessarily performed, except those mandated by government requirements.

Certain applications using semiconductor products may involve potential risks of death, personal injury, or severe property or environmental damage ("Critical Applications").

TI SEMICONDUCTOR PRODUCTS ARE NOT DESIGNED, INTENDED, AUTHORIZED, OR WARRANTED TO BE SUITABLE FOR USE IN LIFE-SUPPORT APPLICATIONS, DEVICES OR SYSTEMS OR OTHER CRITICAL APPLICATIONS.

Inclusion of TI products in such applications is understood to be fully at the risk of the customer. Use of TI products in such applications requires the written approval of an appropriate TI officer. Questions concerning potential risk applications should be directed to TI through a local SC sales office.

In order to minimize risks associated with the customer's applications, adequate design and operating safeguards should be provided by the customer to minimize inherent or procedural hazards.

TI assumes no liability for applications assistance, customer product design, software performance, or infringement of patents or services described herein. Nor does TI warrant or represent that any license, either express or implied, is granted under any patent right, copyright, mask work right, or other intellectual property right of TI covering or relating to any combination, machine, or process in which such semiconductor products or services might be or are used.

Copyright © 1996, Texas Instruments Incorporated